

Dear Exhibitor,

CSI is pleased to offer the services contained in our Exhibitor Service Kit for the **Successful Aging & Travel Expo 2018** being held at **West World of Scottsdale** on **September 29th - 30th, 2018**. Our primary goal is to provide the exhibitor with a professional, seamless and positive show experience.

As you review our Exhibitor Service Kit, you will see many services and equipment, most of which can be ordered online. Once at the CSI ordering system, please enter your email address. If there is anything that you require that is not listed, please contact our Exhibitor Service Department at cs@meetcsi.com or 800-471-7330, and we will do our very best to accommodate you. We encourage you to order early to take advantage of our discounted pricing (Please see the payment policy page.)

CSI will be onsite at the CSI Service Desk during move-in and move-out to assist with any last-minute needs and to answer any questions you may have.

We look forward to being of service to you and wish you great success with the show.

Yours Truly,
CSI Exhibitor Service Department

SHOW INFORMATION

- BOOTH PACKAGE:** Each 10' x 10' booth is equipped with; 8' high back drape, 3' high side rail, 1- 6' skirted table, 2- chairs, 1- wastebasket, and 1 Identification Sign.
- SHOW COLORS:** **BLACK**
- BOOTH CARPET:** The West World of Scottsdale is not carpeted; however, carpet is available to order to match your company color & booth theme through CSI

SHOW SCHEDULE

Exhibitor Move-in:	Friday, September 28 th , 2018
Time:	1:30PM – 6:30PM
Exhibitor Move-in:	Saturday, September 29 th , 2018
Time:	7:30AM – 9:00AM
Exhibit Hours:	Saturday, September 29 th , 2018
Time:	10:00AM – 4:00PM
Exhibit Hours:	Sunday, September 30 th , 2018
Time:	10:00AM – 4:00PM
Exhibitor Move-out:	Sunday, September 30 th , 2018
Time:	4:00PM – 8:00PM
Empties Will Be Returned After:	4:00PM
Carrier Check In:	5:00PM

DEADLINE DATES

Discount Deadline Date:	9/14/18
Advance Shipments Can Begin to Arrive:	8/25/18
Last Day for Advance Shipments without a Surcharge:	9/25/18

SHIPPING

ADVANCE SHIPMENT

Shipments to arrive between (8/27 - 9/25) without late surcharge
Company Name & Booth Number
Successful Aging & Travel Expo 2018
c/o CSI
4802 W. Van Buren Street
Phoenix, Arizona 85043

DIRECT SHIPMENTS- Highly Discouraged

To arrive **ONLY** during **MOVE-IN** hours 1:30PM-5:00PM on 9/28/18
Company Name & Booth Number
Successful Aging & Travel Expo 2018
c/o CSI
West World of Scottsdale
16601 N. Pima Rd.
Scottsdale, AZ 85260

ORDER SUMMARY/PAYMENT AUTHORIZATION FORM

EXHIBITOR INFORMATION

BOOTH NUMBER: _____
COMPANY NAME: _____
CONTACT NAME: _____
ADDRESS: _____

 CITY, STATE Zip
PHONE: _____ **FAX:** _____
EMAIL: _____

ORDER SUMMARY (TOTAL FROM ORDER FORMS)

MATERIAL HANDLING (ESTIMATED) CARTLOAD _____ *SHIPPING _____ *CARPET & DRAPE _____ *TABLES _____ *BOOTH ACCESSORIES _____ *EXTRA STEEL _____	* RENTAL DISPLAY _____ *RENTAL DISPLAY & ACCESSORIES _____ SLATWALL & GRIDWALL _____ BOOTH CLEANING _____ LABOR _____ IN BOOTH FORKLIFT _____ LONG TERM STORAGE SERVICE _____
TOTAL ESTIMATED CHARGES: _____ *PLUS SALES TAX 8.6% _____ (include sales tax where applicable): _____ Surcharge 4%: _____ GRAND TOTAL: _____	

NOTE: All Material Handling, Labor, and Storage orders require a credit card on file for any additional handling charges or overages.

CREDIT CARD AUTHORIZATION	
Card Type: AMEX VISA MC DISC	Card# <input style="width: 100%;" type="text"/>
Name on Card: _____	
Billing Address: _____	
(REQUIRED)	Zip <input style="width: 100%;" type="text"/>
City: <input style="width: 100%;" type="text"/>	State: <input style="width: 100%;" type="text"/>
Expiration Date: <input style="width: 100%;" type="text"/>	Card Verification # <input style="width: 100%;" type="text"/>
Cardholder's Signature: _____	Date: _____
The above signatory authorizes the credit card to be charged for the above orders, plus any additional charges or balances due for material handling or labor during the event. The signatory has read and agrees to the CSI Payment Policy included in the Exhibitor Kit. A \$50 service charge will be applied should the credit card charges be declined.	

PAYMENT POLICY

CSI requires payment upon receipt of all orders for materials and services listed in the Exhibitor Service Kit. We encourage the exhibitors to place their orders online on our secure website. We require a credit card on file for any additional charges or balances due for incidental items, material handling, or labor incurred during the show. All unpaid balances must be paid prior to the closing of the show.

Discount Pricing

CSI Exhibitor Service Kit provides both discounted and standard pricing. To take advantage of the discounted pricing orders must be received, with payment in full, no later than Deadline dates.

Discount Deadline Date: **9/14/18**

Material Handling Deadline- Last Day for Advance Shipments

without a Surcharge: **9/25/18**

Method of Payment

For your convenience, we accept checks, VISA, MasterCard, American Express and Discover Cards. Please make checks payable to Conference Services International. Purchase orders are not considered payments. All payments must be made in US funds. Exhibitors will be charged a \$50.00 fee for NSF Checks.

NOTE: All Material Handling and Labor orders require a credit card on file for any additional handling charges or overages.

Cancellation/Refund Policies

Exhibitors may cancel or revise their orders up to 30 days prior to show move-in at no charge. Cancellations made within 30 days of the move-in, up to the day preceding the move-in, are invoiced at 50% of original price. Any cancellations on the day of move-in will be invoiced 100% of the full cost.

- **Please Note: Furniture included in booth package by Show Management cannot be credited. However, changes can be made at the Exhibitor's expense.**
- **No refunds will be issued on pre-order rentals that are missing from the booth space. These rental items will be charged in full if not brought to the attention of CSI personnel prior to show opening.**

Tax Exemption

If tax exempt, please submit a copy of your tax-exempt certificate with all orders. Tax exempt certificate must be for the State of Arizona to apply. You will be charged tax if your forms are not received prior to deadline.

IMPORTANT INBOUND MATERIAL HANDLING/SHIPPING INSTRUCTIONS

It is the responsibility of the exhibiting company to arrange any and all shipments to the CSI warehouse or the Venue.

Advance Shipments - Receiving begins 30 days prior to exhibitor move-in. Shipments must arrive at the warehouse no later than **9/25/18**. Shipments arriving after that date will be received; however additional charges per the attached rate sheet will be incurred. Warehouse receiving hours are **Monday-Friday 8:00AM-4:30PM (closed all major holidays)**. Shipments arriving outside of those hours will incur additional charges per the attached rate sheet.

DO NOT SHIP YOUR MATERIALS TO THE VENUE PRIOR TO THE ASSIGNED EXHIBITOR MOVE IN DATE OF: 9/28/18

Direct Shipments – Highly discouraged. Shipments that must be directed to show site can only arrive at **during exhibitor move in hours**. Early shipments may be refused. CSI is not responsible, for loss or damages, for shipments that are delivered to the Venue prior to that date. **Items shipped directly to show site and handled by CSI personnel will be charged drayage/material handling per the rate sheet enclosed. Additional West World of Scottsdale fees may apply.**

Consolidate your shipment and save - Separate shipments received by CSI will not be combined. The minimum 200lb charge applies to each shipment that CSI receives. Shipments arriving at the same time from different destinations are considered separate shipments. Please be aware that FedEx and UPS may split shipments resulting in CSI receiving multiple shipments.

ALL SHIPMENTS MUST BE SENT PRE-PAID; NO COD'S WILL BE ACCEPTED.

Outbound shipments - Outbound shipping is not an automatic process. Outbound Bills of Lading must be completed and turned in to the CSI Service Desk. **Do not leave outbound Bills of Lading in your booth.** Exhibitors who wish to ship outbound materials via any carrier other than the official show carrier must make arrangements with their carrier to be checked in at the CSI Service Desk by the driver check-in time specified on the *Show Information* page. Drivers are placed in line for loading on a first come, first serve basis, provided the exhibitor is completely packed and a Bill of Lading has been turned in to the Service Desk. Drivers whose Bills of Lading have not been turned in will be placed in a holding queue until the booth is packed and the Bill of Lading is turned in. Should your carrier fail to check in by the designated time or refuses to pick up your shipment, CSI reserves the right to re-route shipment via the official show carrier as necessary, at the exhibitor's expense.

NOTE: Any items left on the show floor will either be brought back to the CSI warehouse and additional charges will be incurred or re-routed with CSI's designated carrier. By shipping your products to CSI and/or the West World of Scottsdale, you agree to the terms and conditions outlined in the Limits of Liability section of the service kit.

MATERIAL HANDLING RATES & ORDER FORM

MATERIAL HANDLING SERVICES:

Includes delivery to the West World of Scottsdale, delivery to your booth, storage of empty containers during show, return of containers to your booth at close of show, moving goods to the dock, and loading onto outbound carrier.

Advance Shipments – Stored up to 30 days prior to show move-in. All shipments received at the warehouse after **9/25/18**, are subject to additional late shipment charges.

Direct Shipments – Highly discouraged. Are accepted during exhibitor move-in hours ONLY. **Early shipments may be refused. Additional West World of Scottsdale fees may apply.**

MATERIAL HANDLING FEES:

Small Packages: A shipment of any number of pieces, with a combined weight not to exceed 50lbs total, that is received on the same day, from the same shipper, and delivered by the same carrier. Small package carriers may split shipments resulting in CSI receiving multiple shipments (on multiple days), resulting in additional material handling fees.

Crated: Materials that are skidded or is in any type of shipping container that can be loaded at the dock with no additional handling required.

Special Handling: Shipments that are crated van line shipments or packed in such a manner as to require special handling, such as ground loading, side door loading, constricted space loading and designated piece loading or stacked shipments. Also included are mixed shipments without certified weight tickets or delivery receipts, such as FedEx, UPS and POV's (personally owned vehicles).

Return to warehouse: All shipments not picked up or routed on a house carrier, if materials are not picked up from the CSI warehouse within 5 days, the exhibitor will incur an additional storage fee.

Late Shipments & Show Site Shipments – Freight received at the warehouse after deadline, or on Show Site are subject to these handling fees.

RATES:	Advanced to Warehouse (8/27 - 9/25):	Late to Warehouse/ Direct to West World of Scottsdale -received after 9/25/18. Highly Discouraged:
Envelope	\$15.50 each	\$23.00 each
Small Packages (50 pounds and less):	\$72.00 per shipment	\$93.00 per shipment
Crated or Skidded (Overtime 1way):	\$83.50 per 100 lbs. (200 lbs. minimum charge), per shipment	\$108.00 per 100 lbs. (200 lbs. minimum charge), per shipment
Special Handling-Uncrated-Mixed:	\$95.00 per 100 lbs. (200 lb. minimum charge), per shipment	\$123.00 per 100 lbs. (200 lbs. minimum charge), per shipment
Return to Warehouse:	\$35.00per 100lbs (\$350.00 minimum charge)	

Late Advance Warehouse/ Direct Shipments (Surcharge) 30% of actual cost or \$30.00 per 100 lbs. 200 lb. minimum, per shipment

Weight tickets must accompany shipments. Re-weigh fees applied if necessary.

	Piece Count	Weight	Carrier Service	Estimated Arrival Date	Estimated Handling Fees
1st Shipments	_____	_____	_____	_____	_____
2nd Shipment	_____	_____	_____	_____	_____
3rd Shipment	_____	_____	_____	_____	_____

Shipments arriving the same day, from different shippers, are considered separate shipments and will be billed separately.

ADVANCE SHIPMENTS	DIRECT SHIPMENTS- Highly Discouraged
Shipments to arrive between (8/27 - 9/25) without late surcharge	To arrive ONLY during MOVE-IN hours 1:30PM – 5:00PM on 9/28/18
Company Name & Booth Number	Company Name & Booth Number
Successful Aging & Travel Expo 2018	Successful Aging & Travel Expo 2018
c/o CSI	c/o CSI
4802 W. Van Buren Street	West World of Scottsdale
Phoenix, Arizona 85043	16601 N. Pima Rd.
	Scottsdale, AZ 85260

TERMS & CONDITIONS: Material handling charges must be paid by credit card (see Order Summary/Payment Authorization form). All shipments, whether shipped in advance or direct to the show site, are subject to the above material handling fees. Please round up to the nearest 100 lbs. when calculating weight. CSI reserves the right to make adjustments to estimates made online or faxed in. Final charges for Material Handling will be based upon ACTUAL weight. Please be aware of our Payment Policy and Limits of Liability.

**DOT TRANSPORTATION - QUOTE REQUEST
OR CALL (602) 730-8126**

Inbound Shipment

<u>Pick-up Information:</u>		<u>Select Destination: (Please Circle)</u>	
Company Name: _____		<u>Advanced Warehouse:</u> Company Name & Booth # Successful Aging & Travel c/o CSI 4802 W. Van Buren Street Phoenix, AZ 85043	<u>Direct to Show Site:</u> Company Name & Booth # Successful Aging & Travel c/o CSI 16601 N. Pima Rd. Scottsdale, AZ 85260
Contact Name: _____	Phone: _____		
Pick-up Address: _____			
City, ST Zip: _____			
Email Address: _____			

Piece Count	Description	Weight (Subject to Reweigh)	Length (Inches)	Width (Inches)	Height (Inches)	Declared Value Insurance (Optional)

<u>Special Instructions:</u>						
Please Circle all that Apply Inside Pick-up Lift Gate Needed Residential Pick-up Pallet Jack Needed TSA Certified Yes or NO						
Pick-up Date:	Pick-up Time (4 hr. window):	Please Circle Type of Delivery Service: Next Day 2 nd Day Deferred Ground				

Outbound Shipment

<u>Shipping from Show Site:</u>		<u>Destination Information:</u>	
Company Name: _____	Booth #: _____	Company Name: _____	
16601 N. Pima Rd.		Contact: _____	
Scottsdale, AZ 85260		Phone: _____	
Contact Name: _____		Shipping Address: _____	
Phone: _____		City, ST Zip: _____	
Email Address: _____		Email Address: _____	

Piece Count	Description	Weight (Subject to Reweigh)	Length (Inches)	Width (Inches)	Height (Inches)	Declared Value Insurance (Optional)

<u>Special Instructions:</u>						
Please Circle all that Apply Inside Delivery Lift Gate Needed Residential Delivery Pallet Jack Needed TSA Certified Yes or No						
Delivery Date:	Delivery Time (4 hr. window):	Please Circle Type of Delivery Service: Next Day 2 nd Day Deferred Ground				

ADVANCE SHIPMENT - SHIPPING LABELS

ADVANCE SHIPMENT	SHIP TO:	c/o	CSI CONFERENCE SERVICES <small>INTL</small> <small>TRADE SHOWS • EXHIBITS • EVENTS</small>	
	Advance Warehouse Cut		4802 W. Van Buren Street	
	Off 9/25/18		Phoenix, AZ 85043	
	Successful Aging & Travel Expo 2018			
	COMPANY EXHIBIT NAME:			_____
	BOOTH NUMBER			_____
PIECE COUNT:		OF	_____	

-----Attach a label to each piece-----

ADVANCE SHIPMENT	SHIP TO:	c/o	CSI CONFERENCE SERVICES <small>INTL</small> <small>TRADE SHOWS • EXHIBITS • EVENTS</small>	
	Advance Warehouse Cut		4802 W. Van Buren Street	
	Off 9/25/18		Phoenix, AZ 85043	
	Successful Aging & Travel Expo 2018			
	COMPANY EXHIBIT NAME:			_____
	BOOTH NUMBER			_____
PIECE COUNT:		OF	_____	

To ensure proper delivery, please attach a label to each container.
Please verify that you are using the correct label:

DIRECT SHIPMENT - SHIPPING LABELS

DIRECT SHIPMENT TO THE WEST WORLD OF SCOTTSDALE ~During Exhibitor Move-in ONLY~	SHIP TO: C/O	 <small>TRADE SHOWS • EXHIBITS • EVENTS</small>	
	Direct Shipping Must Arrive During 9/28/18 Only.		West World of Scottsdale 16601 N. Pima Rd. Scottsdale, AZ 85260
		Successful Aging & Travel Expo 2018	
	COMPANY EXHIBIT NAME:	_____	
	BOOTH NUMBER	_____	
	PIECE COUNT:	OF	_____

-----Attach a label to each piece-----

DIRECT SHIPMENT TO THE WEST WORLD OF SCOTTSDALE ~During Exhibitor Move-in ONLY~	SHIP TO: C/O	 <small>TRADE SHOWS • EXHIBITS • EVENTS</small>	
	Direct Shipping Must Arrive During 9/28/18 Only.		West World of Scottsdale 16601 N. Pima Rd. Scottsdale, AZ 85260
		Successful Aging & Travel Expo 2018	
	COMPANY EXHIBIT NAME:	_____	
	BOOTH NUMBER	_____	
	PIECE COUNT:	OF	_____

To ensure proper delivery, please attach a label to each container.
 Please verify that you are using the correct label:

OUTBOUND SHIPPING INSTRUCTIONS

EVERY OUTBOUND SHIPMENT WILL REQUIRE A MATERIAL HANDLING AGREEMENT AND LABELS. WE ARE HAPPY TO PREPARE THESE FOR YOU IN ADVANCE. TO TAKE ADVANTAGE OF THIS FREE SERVICE, PLEASE COMPLETE AND RETURN THIS FORM PRIOR TO EVENT MOVE IN.

SHIPPING INFORMATION			
FROM:	EXHIBITING COMPANY NAME:	BOOTH:	
	WEST WORLD OF SCOTTSDALE:	16601 N. Pima Rd.	
		Scottsdale,	AZ 85260

SHIPPING DESTINATION 1: ENTER DESIRED # OF SHIPPING LABELS _____			
TO:	COMPANY NAME:		
	DELIVERY ADDRESS:		
		CITY,	STATE
		ZIP	
	PHONE:	ATTN:	
Please Check Mark Desired Method of Shipment Below:			
Carrier:	<input type="checkbox"/> CSI Preferred Carrier- D.O.T	<input type="checkbox"/> Other (arranged by Exhibitor):	_____
Standard Delivery: 8:00AM – 5:00PM (M-F)			
Delivery Method	Special Requirements	Alternative Method:	
<input type="checkbox"/> Next Day	<input type="checkbox"/> Inside Delivery	In the event shipment has not been picked up by show deadline, D.O.T. is Authorized to:	
<input type="checkbox"/> 2 nd Day	<input type="checkbox"/> Residential		
<input type="checkbox"/> Deferred	<input type="checkbox"/> Lift Gate		
<input type="checkbox"/> Ground	<input type="checkbox"/> Other: _____		
		<input type="checkbox"/> Return shipment to warehouse (if applicable)- \$350.00 Min. charge	

SHIPPING DESTINATION 2: ENTER DESIRED # OF SHIPPING LABELS _____			
TO:	COMPANY NAME:		
	DELIVERY ADDRESS:		
		CITY,	STATE
		ZIP	
	PHONE:	ATTN:	
Please Check Mark Desired Method of Shipment Below:			
Carrier:	<input type="checkbox"/> CSI Preferred Carrier- D.O.T	<input type="checkbox"/> Other (arranged by Exhibitor):	_____
Standard Delivery: 8:00AM – 5:00PM (M-F)			
Delivery Method:	Special Requirements	Alternative Method:	
<input type="checkbox"/> Next Day	<input type="checkbox"/> Inside Delivery	In the event shipment has not been picked up by show deadline, D.O.T. is Authorized to:	
<input type="checkbox"/> 2 nd Day	<input type="checkbox"/> Residential		
<input type="checkbox"/> Deferred	<input type="checkbox"/> Lift Gate		
<input type="checkbox"/> Ground	<input type="checkbox"/> Other: _____		
		<input type="checkbox"/> Return shipment to warehouse (if applicable)- \$350.00 Min. charge	

Once your shipment is packed and ready to be picked up, please return the outbound bill of lading to the CSI Service Desk on the show floor. Shipments without paperwork turned in will be returned to the CSI Warehouse or forced onto another carrier at Exhibitor's expense. All shipments not picked up or routed on in house carrier will incur a return to warehouse fee of \$35.00 per 100 weight; with a \$350.00 minimum charge. CSI does not accept responsibility for any exhibitor property left on the show floor unattended at any time for any reason. If materials are not picked up from the CSI warehouse within 5 days, exhibitor will incur a storage fee.

EXHIBIT MOVE-OUT NOTICE

PRIOR TO CLOSE OF SHOW:

- Stop by the CSI Service Desk to pick up your Bill of Lading for outbound shipping.
- Any and all outbound shipments regardless of carrier (including POV's) **MUST** have completed a Bill of Lading returned to the Service Desk prior to leaving show site.
- **All balances must be paid in full.**
- CSI Service Desk will be manned 1 hour prior to close of the show to assist with shipping needs.
Note: Material Handling Charges will apply to all shipments.

SHOW CLOSING:

- For your safety, do not dismantle your booth until the show officially closes.
- If there is aisle carpet, please do not place any items in the aisle as ALL aisle carpet will be rolled up and removed immediately upon the close of the show.
- **EMPTY CONTAINERS WILL BE RETURNED AFTER THE SHOW CLOSES AND ALL AISLE CARPET HAS BEEN ROLLED UP (if applicable). TO EXPEDITE THIS PROCESS, PLEASE KEEP THE AISLES CLEAR AND YOUR ITEMS INSIDE YOUR BOOTH SPACE.**
- Exhibitors are not allowed to search in trailers, storage or other areas not designated as common areas.

SHIPPING OF MATERIALS:

When your materials return from empty storage, remove all old shipping and "empty" labels. Be certain each box is labeled with the NEW DESTINATION ADDRESS. Blank shipping labels are available at the **CSI Service Desk**.

- When done packing, leave shipments in your booth space.
- If you have multiple boxes/cases, group the portions together so a stray piece will not be overlooked.
- Return completed Bill of Lading to **CSI Service Desk** once you are packed & ready to ship.
- If you are using any outside carrier, including **UPS or FEDEX**, you **MUST** call them to arrange on-site pick up.
Be advised that most carriers do not pick up after regular business hours (i.e. Weekends or after 5pm on weekdays)
- Any shipments left on the show floor, REGARDLESS OF CARRIER, must have completed Bill of Lading.
- If outside carriers do not arrive to pick up shipments by the carrier check-in time of _____, shipments will be rerouted using one of our preferred carriers or returned to the CSI warehouse (if applicable), with a fee charged to the exhibitor.
- The Venue must be cleared during move out; NO shipments can be left on the show floor for later pick-up.

THANK YOU!

All outbound carriers must be checked in no later than

Official On-site Carrier:



TRADE SHOWS • EXHIBITS • EVENTS

CSI LOGISTICS - SHIPPING MADE EASY

CARTLOAD SERVICE ORDER FORM

Received by 9/14/18

Special Freight Services – Small Passenger Vehicles Only!

This service is offered exclusively for this show.

- To facilitate the move-in and move-out of Exhibitors with small exhibit material shipments, CSI is pleased to make available for hire, one (1) laborer with one (1) pushcart, for one (1) trip. Services can be made one way from the dock to your booth or your booth to the dock. Charges for these services are \$25.00 each way.
- This service is for those who have small hand carry items all of which must fit on a 3' x 4' push cart, in one trip only. If you arrive with a truck, van, trailer, or truck with trailer filled with exhibit material you will not qualify for this service and will be redirected.
- A cartload is anything weighing 200 lbs. or less total. There is one cartload allowed per booth.
- Your vehicle must unload on the receiving dock of the exhibit hall. CSI personnel will direct vehicles. The cart is not authorized to enter or go to any parking structure. There must be two (2) people with the vehicle; one person to go with your product to the booth space and one person to remove your vehicle from the unloading area to the parking area.
- Freight that is too large or heavy will be charged material handling rates. No personal trucks (one (1) ton & over), no rental trucks, trailers, or bobtails will be unloaded through cartload service.
- Pre-orders will receive preferential service at show site; you may also order this service at the CSI Service Desk.

Return with Payment & Credit Card Charge Authorization form
Exhibitors may not use carts without authorization by a CSI manager.

All orders are governed by CSI Payment Policy, and Terms & Conditions of Contract as specified in this Exhibitor Services Kit.

Cart Load Service			
Description	Price	Number of Trips to booth	Total Price
Dock to Booth	\$25.00	_____	\$ _____
Booth to Dock	\$25.00	_____	\$ _____
		Grand total	
In placing this order, I have agreed and accepted CSI Payment Policy and the Terms & Conditions of Contract.			
Authorized Signature			
Authorized Name (Please Print)			Date

Exhibitor Information

Company Name: _____
Phone: _____

Booth Number: _____
Contact: _____
Fax: _____

CARPET & DRAPE ORDER FORM

All rental carpets ordered from CSI are installed in clean condition. Any cleaning services required within your booth space for debris accumulated during set-up and exhibit hours should be ordered additionally from the Booth Cleaning order form.

<u>QTY</u>	<u>STANDARD CARPET</u>	<u>DISCOUNT</u>	<u>STANDARD</u>	<u>SUBTOTAL</u>
Carpet Colors: Black, Blue, Burgundy, Gray, Green, Red				
10' x 10' CARPET	COLOR: _____	\$105.00	\$126.00	_____
10' X 20' CARPET	COLOR: _____	\$210.00	\$252.00	_____
10' X 30' CARPET	COLOR: _____	\$315.00	\$378.00	_____
10' X 40' CARPET	COLOR: _____	\$420.00	\$504.00	_____
STANDARD SPECIAL CUT (16 oz.):		SQ FEET	RATE	SUBTOTAL
_____ Ft.	X _____ Ft.	_____	\$2.85 sq. ft.	_____
<u>PREMIUM CARPET (100 Sq. ft. minimum charge)</u>		<u>TOTAL SQ. FEET</u>	<u>RATE</u>	<u>SUBTOTAL</u>
Designer Plus Colors: Beige, Black, Bronze, Burgundy, Cobalt, Chocolate, Dove, Emerald, Mocha, Navy, Ivory, White, Red, Royal Blue, Sapphire, Terra Cotta				
Designer Plus (26 oz.)	COLOR: _____	_____	\$5.40 sq. ft.	_____
Supreme Colors: Red, Black, White, Charcoal, Silver Cloud, Navy, Emerald, Wheat, Reflex Blue				
Supreme (45 oz.)	COLOR: _____	_____	\$6.70 sq. ft.	_____
Matrix Carpet Colors: Blue Jay, Cayenne, Pepper, Rain Forest, Safari				
Matrix	COLOR: _____	_____	\$5.15 sq. ft.	_____
<u>CARPET ACCESSORIES</u>		<u>TOTAL SQ. FEET</u>	<u>RATE</u>	<u>SUBTOTAL</u>
CARPET PADDING				
_____ ft.	X _____ Ft.	(100 sq. ft. minimum charge)	\$1.35 sq. ft.	_____
VISQUEEN CARPET COVERING (carpet protection)				
_____ Ft.	X _____ Ft.	(100 sq. ft. minimum charge)	\$0.80 sq. ft.	_____
<u>QTY</u>	<u>DRAPE (in addition to what is provided)</u>	<u>DISCOUNT</u>	<u>STANDARD</u>	<u>SUBTOTAL</u>
Drape Colors: Black, Blue, Burgundy, Red, Silver, Green, Teal, Plum				
10' Section of 3' HIGH DRAPE, includes steel.	COLOR: _____	\$64.00	\$80.00	_____
10' Section of 8' HIGH DRAPE, includes steel.	COLOR: _____	\$134.00	\$164.00	_____
TERMS & CONDITIONS To receive Discount Rate, orders must be received & paid for by 9/14/18. orders will be charged at 50% of total if cancelled within 30 days of move-in. Cancelled orders will be charged 100% of total if cancelled after move-in begins. Orders must be paid by credit card (see Order Summary/Payment Authorization Form). No refunds will be issued on pre-order rentals that are missing from booth spaces. These rental items will be charged in full if not brought to the attention of the CSI Service Desk during exhibitor move-in.			Sub Total	\$ _____
			Sales Tax 8.6%	\$ _____
			4% Fee	\$ _____
			Total Due	\$ _____

Exhibitor Information

Company Name: _____ Contact: _____ Booth Number: _____
 Phone: _____ Fax: _____

Standard Carpet

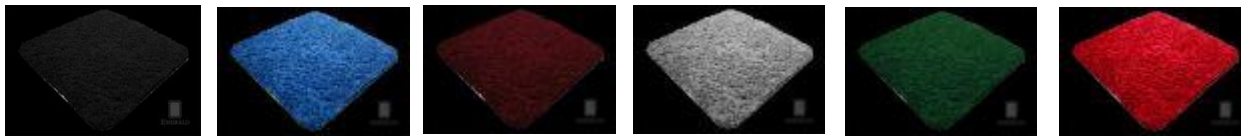

Black Blue Burgundy Grey Green Red

PREMIUM CARPET SELECTION:

(Premium carpet requires two weeks to process. Call prior to ordering.)

Designer Plus Carpet

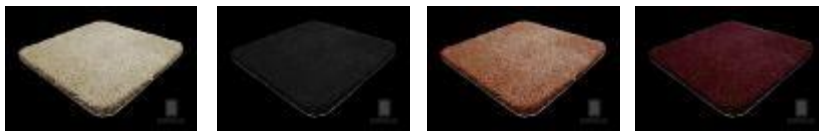

Beige Black Bronze Burgundy

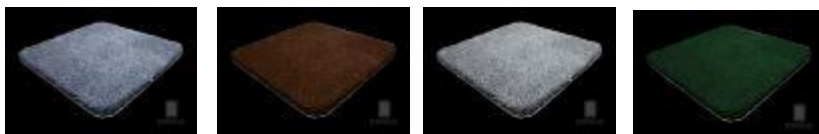

Cobalt Chocolate Dove Emerald

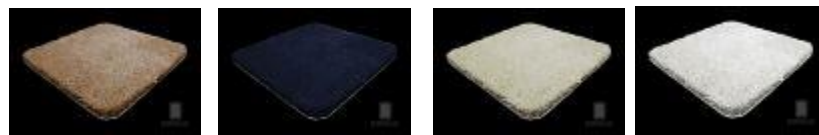

Mocha Navy Ivory White

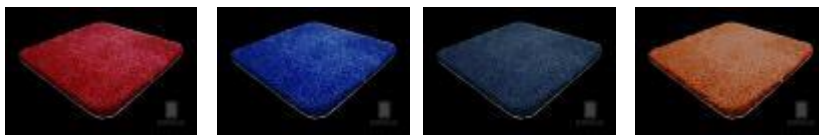

Red Royal Blue Sapphire Terra Cotta

Matrix Carpet



Blue Jay Rain Forest



Cayenne Pepper



Safari

Supreme Carpet



Red Black White Charcoal Silver Cloud Navy Emerald

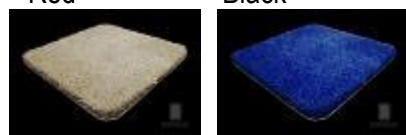

Wheat Reflex Blue

CLEANING ORDER FORM

CLEANING SERVICES

- All rental carpets ordered from CSI are installed in clean condition. Any cleaning services required within your booth space for debris accumulated during set-up and exhibit hours should be ordered below.
- Prices are based on total square footage of booth regardless of area to be cleaned.

CLEANING RATES (per sq. ft. – 100 sq. ft. minimum)

Vacuum daily of booth carpet – before initial show opening, and daily thereafter.

_____	x	_____	x	Price \$0.43 sq. ft.	=	Subtotal _____
100 square feet minimum order		Total Number of Days				

Vacuum Once – before initial show opening only.

_____	x	_____	x	Price \$0.46 sq. ft.	=	Subtotal _____
100 square feet minimum order		Total Number of Days				

<p>TERMS & CONDITIONS To receive Discount Rate, orders must be received & paid for by 9/14/18. orders will be charged at 50% of total if cancelled within 30 days of move-in. Cancelled orders will be charged 100% of total if cancelled after move-in begins. Orders must be paid by credit card (see Order Summary/Payment Authorization Form). No refunds will be issued on pre-order rentals that are missing from booth spaces. These rental items will be charged in full if not brought to the attention of the CSI Service Desk during exhibitor move-in.</p>	Sub Total	\$ _____
	Sales Tax 8.6%	Not Applicable
	4% Fee	\$ _____
	Total	\$ _____

Exhibitor Information

Company Name: _____
Phone: _____

Booth Number: _____
Contact: _____
Fax: _____

TABLE ORDER FORM

UNSKIRTED TABLES

QTY	TABLES ~ UNSKIRTED	30"H	40"H	DISCOUNT	STANDARD
	4' X 2' UNSKIRTED TABLE			\$40.00	\$48.00
	6' X 2' UNSKIRTED TABLE			\$46.00	\$55.00
	8' X 2' UNSKIRTED TABLE			\$53.00	\$64.00



SKIRTED TABLES

QTY	TABLES ~ SKIRTED	30"H	40" H	DISCOUNT	STANDARD
	4' X 2' SKIRTED TABLE			\$55.00	\$66.00
	6' X 2' SKIRTED TABLE			\$63.00	\$76.00
	8' X 2' SKIRTED TABLE			\$72.00	\$86.00
	Skirt all four sides			\$35.00	\$40.00

SKIRT COLORS:





TABLE RISERS

QTY	TABLE RISERS	DISCOUNT	STANDARD
	4' X 12" TABLE RISER w/white cover	\$34.00	\$43.00
	6' x 12" TABLE RISER w/white cover	\$41.00	\$52.00
	8' X 12" TABLE RISER w/ white cover	\$50.00	\$63.00



TERMS & CONDITIONS

To receive Discount Rate, orders must be received & paid for By 9/14/18.
orders will be charged at 50% of total if cancelled within 30 days of move-in.
Cancelled orders will be charged 100% of total if cancelled after move-in begins.
Orders must be paid by credit card (see Order Summary/Payment Authorization Form).
No refunds will be issued on pre-order rentals that are missing from booth spaces. These rental items will be charged in full if not brought to the attention of the CSI Service Desk during exhibitor move-in.

Sub Total	\$
Sales Tax 8.6%	\$
4% Fee	\$
Total Due	\$





Exhibitor Information

Company Name: _____
Phone: _____

Booth Number: _____

Contact: _____
Fax: _____

FURNITURE ORDER FORM

CHAIRS							
QTY		DISCOUNT	STANDARD	QTY		DISCOUNT	STANDARD
	MOLDED SIDE CHAIR 	\$25.00	\$40.00		PADDED ARM CHAIR 	\$45.00	\$60.00
	PADDED SIDE CHAIR 	\$35.00	\$50.00		PADDED STOOL 	\$55.00	\$70.00

ACCESSORIES			
QTY		DISCOUNT	STANDARD
	WASTEBASKET	\$15.00	\$18.00
	EASEL	\$38.00	\$46.00
	PEDESTAL TABLE – 36" D X 30" H (COCKTAIL)	\$100.00	\$120.00
	PEDESTAL TABLE – 36" D X 40" H (COCKTAIL)	\$115.00	\$138.00
	LINEN FOR 30" HIGH PEDESTAL <input type="checkbox"/> White <input type="checkbox"/> Black	\$20.00	N/A
	LINEN FOR 40" HIGH PEDESTAL <input type="checkbox"/> White <input type="checkbox"/> Black	\$25.00	N/A
	BAG RACK	\$57.00	\$69.00
	WATERFALL RACK	\$67.00	\$81.00
	GARMENT RACK	\$81.00	\$98.00
	BLACK GARMENT RACK – NON-ROLLING	\$95.00	\$114.00
	STANCHION w/ RETRACTABLE BELT	\$44.00	\$53.00
	LITERATURE RACK	\$70.00	\$84.00
	TICKET TUMBLER	\$72.00	\$86.00
	SIGN STAND (22" X 28")	\$63.00	\$76.00
	TACKBOARD (4' X 6') Velcro & pushpin compatible	\$120.00	\$114.00
	TACKBOARD (4' X 8') Velcro & pushpin compatible	\$130.00	\$156.00
	BANDING (PER PALLET)	\$25.00	\$35.00
	SHRINK WRAP (PER PALLET)	\$25.00	\$35.00
TERMS & CONDITIONS To receive Discount Rate, orders must be received & paid for by 9/14/18. orders will be charged at 50% of total if cancelled within 30 days of move-in. Cancelled orders will be charged 100% of total if cancelled after move-in begins. Orders must be paid by credit card (see Order Summary/Payment Authorization Form). No refunds will be issued on pre-order rentals that are missing from booth spaces. These rental items will be charged in full if not brought to the attention of the CSI Service Desk during exhibitor move-in.			Sub Total \$ Sales Tax 8.6% \$ 4% fee \$ Total Due \$

Exhibitor Information

Company Name: _____
 Phone: _____

Booth Number: _____
 Contact: _____
 Fax: _____

**FURNITURE
ACCESSORIES**



Wastebasket



Easel



36" D x 40" H
Pedestal



36" D x 30" H
Pedestal



Linen Colors
 Black White
 Black White



Bag Rack



Waterfall Rack



Garment Rack



Black Garment Rack
Non - Rolling



Chrome Stanchion
w/Retractable Belt



Black Literature
Rack (6 slots)



Chrome Sign Stand



Ticket Tumbler

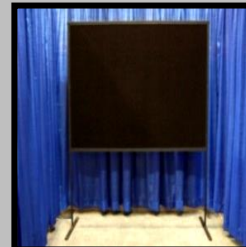

4'x6' or 4'x8' Tackboard
Single or Double Sided

EXTRA STEEL ORDER FORM

Circle your booth size: 8' x 10' 10' x 10' 10' x 20' Other _____

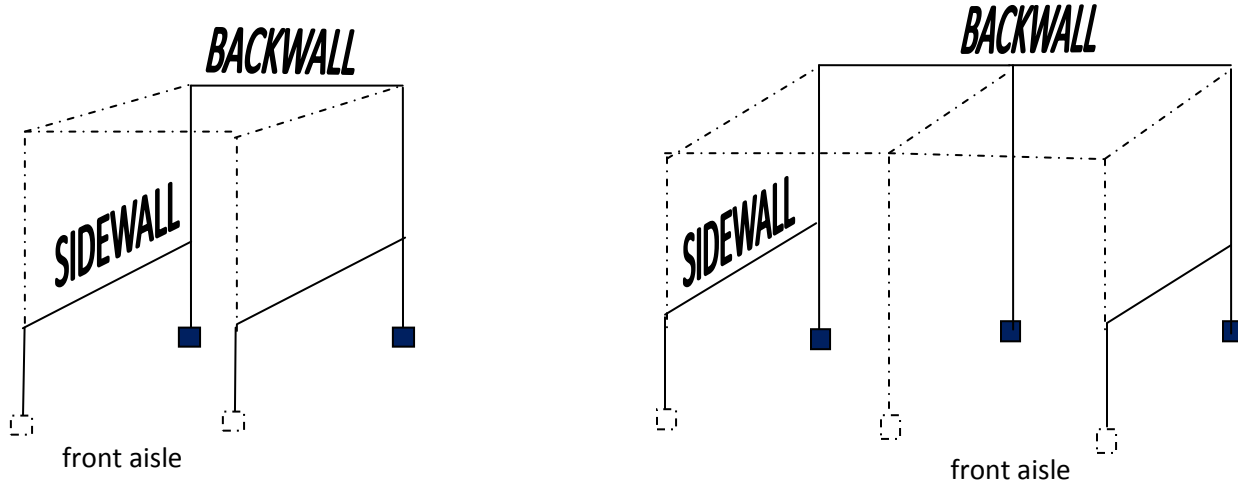

Draw in Extra Steel using the pictures above accordingly:

Apply symbols: XXX=crossbar O=8' pole & base Δ=3' pole & base

Customize Your Booth (enter the quantity):



QTY	ITEM	RATE	SUBTOTAL
	Crossbars	\$11.00	
	8' Pole & Base	\$22.00	
	3' Pole & Base	\$18.00	
TERMS & CONDITIONS		Sub Total	\$
To receive Discount Rate, orders must be received & paid for by 9/14/18.		Sales Tax 8.6%	\$
orders will be charged at 50% of total if cancelled within 30 days of move-in.		4% Fee	\$
Cancelled orders will be charged 100% of total if cancelled after move-in begins.		Total	\$
Orders must be paid by credit card (see Order Summary/Payment Authorization Form).			
No refunds will be issued on pre-order rentals that are missing from booth spaces. These rental items will be charged in full if not brought to the attention of the CSI Service Desk during exhibitor move-in.			

Exhibitor Information

Company Name: _____
Phone: _____

Booth Number: _____
Contact: _____
Fax: _____

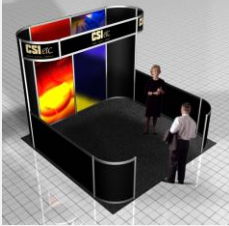
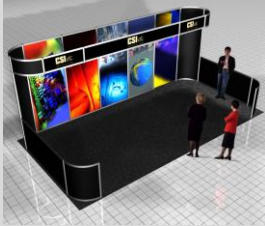
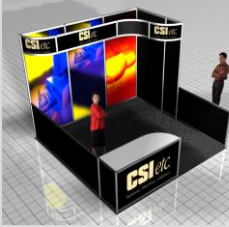
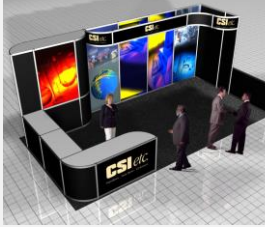
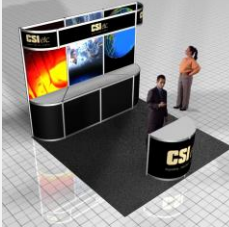
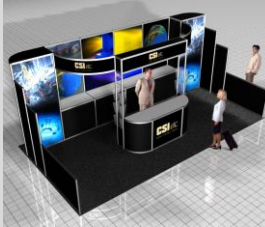
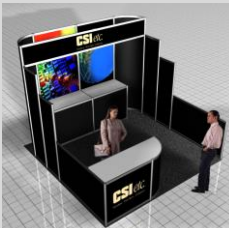
STANDARD RENTAL DISPLAYS

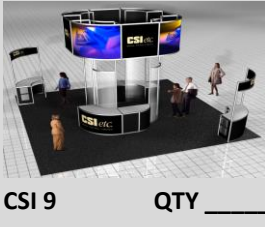
	Discount Rate	Standard Rate		Discount Rate	Standard Rate
 CSI 1 QTY _____	\$2,450.00	\$2,950.00 Please call for graphics quotes	 CSI 5 QTY _____	\$3,900.00	\$4,400.00 Please call for graphics quotes
 CSI 2 QTY _____	\$2,950.00	\$3,450.00 Please call for graphics quote	 CSI 6 QTY _____	\$4,400.00	\$4,900.00 Please call for graphics quote
 CSI 3 QTY _____	\$2,750.00	\$3,250.00 Please call for graphics quote	 CSI 7 QTY _____	\$4,700.00	\$5,100.00 Please call for graphics quote
 CSI 4 QTY _____	\$3,450.00	\$3,950.00 Please call for graphics quote	 CSI 8 QTY _____	\$7,500.00	\$7,900.00 Please call for graphics quote
Standard Booth Includes: <ul style="list-style-type: none"> • Booth Carpet • White or Black Hard Wall Panels • Header with Color Artwork • Delivery to Show Site • Installation/Dismantle Labor • Call for other color options 			 CSI 9 QTY _____	\$8,800.00	\$9,300.00 Please call for graphics quote









Exhibitor Information

Company Name: _____
Phone: _____

Booth Number: _____

Contact: _____
Fax: _____

RENTAL DISPLAY COUNTERS & ACCESSORIES

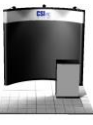
	QTY	DISCOUNT	STANDARD	TOTAL
 1 Meter Counter, white, black or gray panels		\$324.00	\$389.00	
 1 Meter Counter, with Custom Graphics		\$461.00	\$553.00	
 1 ½ Meter Counter, white, black, or gray panels		\$490.00	\$563.50	
 1 ½ Meter Counter, with Custom Graphics		\$691.00	\$829.00	
 2 Meter Counter, white, black, or gray panels		\$654.00	\$785.00	
 2 Meter Counter, with Custom Graphics		\$924.00	\$1,109.00	
 Curved Counter. Call for Graphics Quote			\$489.00	
 Computer Work Station. Call for Graphics Quote			\$650.00	
 Reception Counter. Call for Graphics Quote.			\$500.00	
 POP UP RENTAL DISPLAY - 10' Curved Backwall Display, with Velcro compatible fabric panels. Included: One Case Table and 3 spotlights. Call for Graphics Quote			\$825.00	

Note: All Counters come with one (1) shelf. Locking doors are also available. Please call for pricing

<p>TERMS & CONDITIONS To receive Discount Rate, orders must be received & paid for by 9/14/18. orders will be charged at 50% of total if cancelled within 30 days of move-in. Cancelled orders will be charged 100% of total if cancelled after move-in begins. Orders must be paid by credit card (see Order Summary/Payment Authorization Form). No refunds will be issued on pre-order rentals that are missing from booth spaces. These rental items will be charged in full if not brought to the attention of the CSI Service Desk during exhibitor move-in.</p>	Sub Total (Estimate)	\$
	Sales Tax 8.6%	\$
	4% Fee	\$
	Total	\$







Exhibitor Information

Company Name: _____ Contact: _____ Booth Number: _____
Phone: _____ Fax: _____

SLATWALL & GRIDWALL ORDER FORM

	DESCRIPTION	QTY	DISCOUNT	STANDARD	SUBTOTAL
	1 Meter by 8ft High Slat wall		\$65.00	\$93.00	
	2' x 8' Grid Wall		\$55.00	\$93.00	
	2'x 6' Grid Wall		\$50.00	\$87.00	

ACCESSORIES FOR SLATWALL & GRIDWALL

	Gridwall & Slatwall Brackets (per set of 2)		\$10.50	\$12.50	
	Gridwall & Slatwall Hooks (per set of 2)		\$10.50	\$12.50	
	10" Shelf for both Gridwall & Rental Display Booths.		\$15.00	\$17.00	
	Light - 75-watt black arm light.		\$26.00	\$31.00	
	Half Page Holder		\$15.00	\$17.00	
	Full Page Holder		\$17.00	\$21.00	

TERMS & CONDITIONS

To receive Discount Rate, orders must be received & paid for by 9/14/18.
orders will be charged at 50% of total if cancelled within 30 days of move-in.
Cancelled orders will be charged 100% of total if cancelled after move-in begins.
Orders must be paid by credit card (see Order Summary/Payment Authorization Form).
No refunds will be issued on pre-order rentals that are missing from booth spaces. These rental items will be charged in full if not brought to the attention of the CSI Service Desk during exhibitor move-in.

Sub Total (Estimate)	\$
Sales Tax 8.6%	\$
4% Fee	\$
Total	\$

Exhibitor Information

Company Name: _____ **Contact:** _____ **Booth Number:** _____
Phone: _____ **Fax:** _____

INSTALLATION AND DISMANTLE LABOR ORDER FORM

LABOR RATES	<i>Per person/ Hour Rate</i>	<i>Per person/ Hour Rate</i>	<i>Per person/ Hour Rate</i>	Labor Hours
	Discount	Standard	Floor	
Straight Time	\$88.00	\$101.00	\$116.00	Monday-Friday, 8:00 am to 4:30 pm Monday-Friday, 4:30 pm to Midnight,
Overtime	\$132.00	\$152.00	\$174.00	Saturday – Sunday 8:00 am to Midnight
Double Time	\$176.00	\$197.00	\$232.00	All days Midnight to 8:00 am & All Observed Union Holidays

One-hour minimum charge per laborer. Thereafter, labor is charged in ½ hour increments

SUPERVISION OPTIONS

CSI – Supervision

Supervision is provided by CSI. The charge for the service is 30% of the total labor bill, with a minimum of \$45.00 for each installation & each dismantle. Booth instructions with diagrams are required.

EXHIBITOR – Supervision

All work performed under the direction of the Exhibitor. Exhibitor must meet the laborer at the CSI Service Desk to start labor.

Exhibitor assumes the responsibility and any liability arising from the work performed by union labor under Exhibitor Supervision.

ESTIMATED LABOR ORDER

	DATE	TIME	NUMBER OF LABORER'S	SUPERVISION <small>Please indicate, CSI or Exhibitor Supervision</small>	ESTIMATED # OF HOURS	RATE	SUBTOTAL
INSTALLATION	_____	_____	_____	_____	_____	_____	_____
DISMANTLE	_____	_____	_____	_____	_____	_____	_____
						Total Due	_____

Tools or equipment needed i.e.; ladder, drill etc. _____

Please estimate the number of workers and hours per workers needed for installation and dismantle.
Hours will be calculated to actual hours worked to the original estimate and based upon date received.

Additional labor required will be calculated and invoiced at show site rates.

TERMS & CONDITIONS To receive Discount Rate, orders must be received & paid for by 9/14/18. orders will be charged at 50% of total if cancelled within 30 days of move-in. Cancelled orders will be charged 100% of total if cancelled after move-in begins. Orders must be paid by credit card (see Order Summary/Payment Authorization Form). No refunds will be issued on pre-order rentals that are missing from booth spaces. These rental items will be charged in full if not brought to the attention of the CSI Service Desk during exhibitor move-in.	Sub Total (Estimate)	\$ _____
	Sales Tax 8.6%	Not Applicable
	4% Fee	\$ _____
	Total	\$ _____

Exhibitor Information

Company Name: _____
Phone: _____

Booth Number: _____
Contact: _____
Fax: _____

IN BOOTH FORK LIFT LABOR

FORKLIFT RATES	Hour Rate (Forklift & Operator)	Hour Rate (Forklift & Operator)	Labor Hours
	<u>Discount</u>	<u>Standard</u>	
Straight Time	\$140.00	\$161.00	Monday-Friday; 8:00 am to 4:30 pm
Overtime	\$210.50	\$241.00	Monday-Friday; 4:30 pm -Midnight, Saturday & Sunday; 8:00 am- Midnight
Double Time	\$280.00	\$322.00	All days Midnight to 8:00 am & All Observed Union Holidays

All orders place on show site are 30% above Regular Rate Listed.

One-hour minimum charge per Forklift. Thereafter, labor is charged in ½ hour increments

HELPER RATES (to spot machinery)

	<u>Discount</u>	<u>Standard</u>	
Straight Time	\$88.00	\$101.00	Monday-Friday; 8:00 am to 4:30 pm
Overtime	\$132.00	\$152.00	Monday-Friday; 4:30 pm -Midnight, Saturday & Sunday; 8:00 am -Midnight
Double Time	\$176.00	\$197.00	All days Midnight to 8:00 am & All Observed Union Holidays

All orders place on show site are 30% above Regular Rate Listed.

One Hour Minimum charge per Helper. Thereafter, labor is charges in ½ hour increments

FORKLIFT ORDER						
	NUMBER OF FORKLIFTS	WEIGHT	NUMBER OF HELPERS	DATE	TIME	APPROX HOURS
INSTALLATION	_____	_____	_____	_____	_____	_____
DISMANTLE	_____	_____	_____	_____	_____	_____
DESCRIPTION OF WORK TO BE DONE			SPECIFY OTHER EQUIPMENT NEEDED			
Spotting of equipment			_____ Straps (call for quote)			
Installation/Dismantle of Header			_____ Chains (Call for quote)			
Other _____			_____ Fork Extensions			
			_____ Crane (call for quote)			
			_____ Cage (call for quote)			

Please provide the onsite contact information:

Name: _____

Phone Number: _____

<p>TERMS & CONDITIONS</p> <p>To receive Discount Rate, orders must be received & paid for by 9/14/18. orders will be charged at 50% of total if cancelled within 30 days of move-in. Cancelled orders will be charged 100% of total if cancelled after move-in begins. Orders must be paid by credit card (see Order Summary/Payment Authorization Form). No refunds will be issued on pre-order rentals that are missing from booth spaces. These rental items will be charged in full if not brought to the attention of the CSI Service Desk during exhibitor move-in.</p>	Subtotal: \$ _____
	Sales Tax 8.6%: Not Applicable
	4% Fee: \$ _____
	Total: \$ _____

Exhibitor Information

Company Name: _____

Phone: _____

Booth Number: _____

Contact: _____

Fax: _____

BOOTH LAYOUT FORM

RETURN TO CSI by 9/14/18

Company Name	Phone Number for on Site Contact	E-Mail Address	Booth Number
--------------	----------------------------------	----------------	--------------

This grid must be attached to the following order forms to insure proper placement of items in your booth. Please photocopy as needed.

- Hanging Signs
 Show Cases
 Tack board
 Special Colored Drape

 Standard Exhibit System
 Pad & Carpet

To use this grid:

- Use bold lines to indicate the outline of your booth.
- Indicate the scale of the grid (i.e. 1 square = 1 foot) or indicate the dimensions of your booth
- Mark the adjacent booth numbers or aisle numbers.

BACK OF BOOTH (Indicate Adjacent Booth or Aisle Number: _____)

FRONT OF BOOTH (Indicate Adjacent Booth or Aisle Number: _____)

STORAGE SERVICE ORDER FORM

“Full Service” Storage and Shipping Advantages After the Show

Keep Your Exhibit Materials in Arizona After the Show to Avoid Double Loading and Unnecessary Shipping Costs

Benefits of storing your materials with CSI Long term storage includes:

1. Convenience of less shipping/shipping and handling fees.
2. Receive and hold your equipment and/or exhibition materials- short or long term.
3. Provide delivery services – capable of outbound shipping and/or local delivery to any contractor event.

Storage Rates:	Return to Warehouse- (5 Day MAX hold.)	\$35.00 per 100lbs (\$350.00 minimum charge)
	Long term Storage- per month	minimum charge of \$100.00 per month (1,000lb min charge) (≥ 1,000.00 lb.) \$10.00 cwt

Notes:

- **Long term Storage rates apply to Return to Warehouse shipments AFTER 5 days of failed carrier pickup.**
- **Long Term Storage Clients will be billed automatically on a quarterly basis and provided an electronic receipt.**
- All storage services are subject to CSI Terms and Conditions of Contract and/or Storage Agreement.
- Exhibitors must insure their own goods while in storage even if the storage is provided under a separate contractual agreement. CSI is not liable for damages.
- Failure to pay storage fees after 7 days of balance due date will result in a lien against your property.
- Unpaid/ unclaimed materials will be disposed of after 90 days.

Please select which service you are requesting:

(Check) Yes! Return my exhibition materials to the warehouse for carrier pickup- 5 Day **MAX** hold.

(Check) Yes! Store my exhibition materials in Arizona after this show

Exhibiting Company: _____ Client Name: _____

Email: _____ Telephone: _____

List of items: _____

CREDIT CARD AUTHORIZATION											
Card Type:	AMEX	VISA	MC	DISC	Card#						
Name on Card:	_____										
Billing Address:	_____										
(REQUIRED)									Zip		
City:					State:						
Expiration Date:					Card Verification #						
Cardholder's Signature:									Date:		
<small>The above signatory authorizes the credit card to be charged for the above orders, plus any additional charges or balances due for material handling or labor during the event. The signatory has read and agrees to the CSI Payment Policy included in the Exhibitor Kit. A \$50 service charge will be applied should the credit card charges be declined. Automatic payment will be charged quarterly for long term storage.</small>											

NON-OFFICIAL CONTRACTOR

Show Management has appointed CSI as the official service contractor to perform and provide necessary services and equipment. Should any Exhibitor wish to employ the service of a contractor other than the official contractor, the following conditions must be met.

1. The Exhibitor must inform CSI of the name and address of the contractor and the work to be performed. This information must be received in writing, no later than 30 days prior to the scheduled move-in date, at CSI
2. The Non-Official Contractor to be used by the exhibitor must do the following:
 - A. Provide a Certificate of Insurance with at least the following items: Comprehensive, General Liability not less than \$1,000,000 with respect to injuries to any one person in an occurrence. \$1,000,000 with respect to injuries to more than one person in any one occurrence; and \$1,000,000 with respect to damage of property workman’s Compensation Insurance, including employee’s liability coverage, in a minimum amount not less than \$1,000,000 of individual and/or aggregate coverage. The Insurance Certificate must also include: The Successful Aging & Travel Expo 2018, exhibiting company name, booth number, and the non-official contractors name and phone number.
 - B. Agree to abide by the rules and regulations of the show.
 - C. Agree to abide by all union rules and regulations.
 - D. Information must be received at CSI no later than 30 days prior to the scheduled move in date.
 - E. Identification badges must be worn at all times. Temporary badges will be provided. Badges will be issued only to persons actually used to supervise, install, dismantle, and maintain exhibit-related equipment. All non-official contractors must check-in at the CSI Service Desk prior to setup and dismantle.
 - F. If the Certificate of Insurance and the Notification of Intent (see below) is not supplied to CSI by the 30-day deadline date, the exhibiting firm or non-official contractor will be required to order labor from CSI
3. For services such as electrical, plumbing, telephone, cleaning, drayage, and forklift operation, no contractor, other than the official contractor will be approved. This regulation is made necessary because work is done on equipment and in facilities owned by parties other than the Exhibitor. The Exhibitor shall provide only the material and equipment, which is owned and is to be used in the exhibit space.

NOTIFICATION OF INTENT TO USE NON-OFFICIAL SERVICE CONTRACTOR			
Company Name:	<input style="width: 95%;" type="text"/>	Booth Number:	<input style="width: 95%;" type="text"/>
Contact at Show:	<input style="width: 98%;" type="text"/>		
Non-Official Contractor:	<input style="width: 98%;" type="text"/>		
Address:	<input style="width: 98%;" type="text"/>		
	<input style="width: 45%;" type="text"/>	<input style="width: 20%;" type="text"/>	<input style="width: 35%;" type="text"/>
	City,	State	Zip
Phone:	<input style="width: 45%;" type="text"/>	Fax:	<input style="width: 45%;" type="text"/>
Authorized Signature:	<input style="width: 95%;" type="text"/>		Date: <input style="width: 25%;" type="text"/>

THIRD PARTY AUTHORIZATION FORM

To authorize CSI to invoice a third party for payment of services rendered to exhibitors, both the exhibiting company and the third party must complete this form and return it at least 14 days prior to the show move-in.

Gratuities

CSI requests that exhibitors do not offer gratuities to our employees, as they are paid an excellent wage denoting a professional status. Any request for tips should be brought to the attention of a representative at the CSI Service Desk.

EXHIBITING COMPANY AUTHORIZATION OF THIRD PARTY BILLING

“We understand and agree that we, the exhibiting company, are ultimately responsible for payment of charges and agree to be bound by all terms and conditions as described in the Terms & Conditions sections of this service kit. In the event that the named third party does not discharge payment of the invoice prior to the last day of the show, charges will revert back to the exhibiting company. All invoices are due and payable upon receipt, by either party. The items checked below are to be invoiced to the third party.”

Safety

Standing on chairs, tables or other rental furniture is prohibited. Rental furniture is not made to support standing weight. CSI cannot be responsible for injuries or falls caused by the improper use of furniture. If assistance is required to assemble your exhibit, see an Exhibitor Service Representative at the CSI Service Desk or the enclosed Labor Order form.

Exhibiting Company Information

Exhibiting Company Name: _____ Booth Number: _____
 Exhibiting Company Address: _____
 City/State/Zip: _____
 Phone: _____ Fax: _____ Email: _____

Indicate which services are to be invoiced to the Third party:

All Services I&D Labor/Supervision Material Handling Rental Items Other

Third Party Company Information

Third Party Company Name: _____
 Third Party Address: _____
 City/State/Zip: _____
 Phone: _____ Fax: _____ Email: _____

THIRD PARTY CREDIT CARD AUTHORIZATION

Card Type: AMEX VISA MC DISC										Card# <input type="text"/>									
Name on Card: _____																			
Billing Address: _____																			
(REQUIRED)															Zip <input type="text"/>				
City: <input type="text"/>					State: <input type="text"/>														
Expiration Date: <input type="text"/>					Card Verification # <input type="text"/>														
Cardholder's Signature: _____															Date: _____				

The above signatory authorizes the credit card to be charged for the above orders, plus any additional charges or balances due for material handling or labor during the event. The signatory has read and agrees to the CSI Payment Policy included in the Exhibitor Kit. A \$50 service charge will be applied should the credit card charges be declined.

ARIZONA UNION GUIDELINES AND SAFETY TIPS

To assist you in planning for your participation we are certain you will appreciate knowing in advance that union labor may be required for certain aspects of your exhibit handling. The following is a description of the work rules and an outline of union jurisdiction. CSI has skilled, friendly and quality conscious employees in Arizona available to assist you with most aspects of your exhibiting experience. Arrangements for labor and other services can be made through the forms provided in this exhibitor service kit.

Booth Labor

Currently, we have an agreement with the Local International Alliance of Theatrical and Stage Employees (IATSE). Members of this union claim jurisdiction over all setup and dismantling of exhibits, furniture installation, pipe and drape, hanging of signs and laying of floor coverings and unloading and delivering of all display related materials.

- Exhibitors may use full-time company personnel that will be staffing their exhibit to assist in setup and/or dismantling of their own booths.
- Exhibitors may employ the services of Non-Official Contractors providing the following requirements are met:
 - A. Exhibitors must advise CSI in writing, thirty (30) days prior to setup of the show, of their intent to hire an outside installation and dismantle company or exhibit house to supervise, install, and dismantle their exhibit. The Intent to Use Non-Official Contractor form must be completed by both parties and returned no less than thirty (30) days prior to setup.
 - B. Non-official contractors must furnish proof of adequate insurance, in the form of an original copy of a policy rider listing CSI as an additional insured, furnished by their broker to CSI office no less than thirty (30) days in advance of actual installation dates.
 - C. Non-Official contractors must furnish show management the names, addresses and telephone numbers of key executives for emergency contact.
 - D. All personnel must wear proper identification at show site.
- All non-official installation and dismantle contractors will be allowed on the exhibit floor only during installation & dismantling hours, and must be identified with a temporary work pass, either supplied by show management or the official service contractor.
- Exhibitors that plan to setup and dismantle their own booths or equipment, with their own employees, are not required to fill out the Non-official contractor's form or send in proof of insurance.

Material Handling

Exhibitors are allowed to unload a mini-van, car, station wagon or pick-up. Exhibitors may use hand-operated equipment that the Exhibitor has provided themselves such as, two wheeled hand dollies and four wheeled flat carts. The use of fork trucks, pallet jacks and any other mechanical equipment is not permitted by anyone other than CSI Any crated materials must be handled by union personnel.

FIRE REGULATIONS

BOOTH CONSTRUCTION

- Using other than what has been provided by CSI, i.e. booths, platforms and space dividers, shall be made of materials that are flame resistant or rendered so, to the satisfactory of the Fire Department representatives.
- Coverings for counters or tables used within or as part of the booth shall be flame resistant.
- All electrical wiring and apparatus will be a 3-wire UL type approved.

FIRE RESISTANT TREATMENT

- All decorations, drapes, signs, banners, acoustical materials, cotton, paper, hay, straw, moss, split bamboo, plastic cloth and similar materials shall be flame resistant unless smaller than 1232 square inches or 28" x 44", if separated from other combustibles by a minimum of 12" horizontally and 24" vertically.
- Oil cloth, tar paper, nylon and certain other plastic materials cannot be made flame resistant, and their use is prohibited.

COMBUSTIBLES

- Literature on display shall be limited to reasonable quantities (one-day supply). Reserve supplies shall be kept in closed containers and stored in a neat and compact manner in a location approved by the Fire Department.
- All exhibit and display empty cartons must be stored in an approved drayage area.
- If show is under a 24-hour approved manned security program, automobiles are allowed to retain 1 gallon or less of fuel, and gas caps must be taped. Batteries are to be disconnected and taped.

Storage behind booth back wall is strictly prohibited.

OBSTRUCTIONS

- Aisles and exits, as designated on approved show plans, shall be kept clean, clear, and free of obstacles.
- Booth construction shall be substantial and fixed in position in specified areas for the duration of the show.
- Easels and any signage shall not be placed beyond the booth area into aisles.
- Firefighting equipment shall be provided and maintained in accessible, easily seen locations and may be required to be posted with designation signs.

LIMITS OF LIABILITY

In placing of an order for services and/or equipment by an exhibitor or any agent of the exhibitor shall be construed as an offer subject to acceptance and approval of CSI in its sole discretion. Upon participation of any CSI show or event, the exhibitor and its agents shall be bound by the terms and conditions set forth in sections 1 through 14 below. Likewise, once CSI has accepted and approved the exhibitor's offer, any shipper consigning or delivering a shipment to CSI or its subcontractors on behalf of the Exhibitor shall be bound by the terms and conditions set forth in sections 1 through 14 below.

1. CSI and its subcontractors shall not be liable for damage, loss or delay to uncrated freight, freight improperly packed, glass breakage or concealed damages as determined by CSI
2. Relative to inbound shipments, there may be lapse of time between the delivery of shipment(s) to the booth by CSI or its subcontractors and the arrival of the Exhibitor's representative at the booth. Similarly, relative to outgoing shipment(s), it is possible that there will be a lapse of time between the completion of packing and the actual pickup of material from the booth for loading onto a carrier. It is understood that during such times the shipment(s) will be left in the booths unattended. Therefore, it is agreed that CSI and its subcontractors shall not be liable for the loss of, disappearance of, or damage of any items left in the booth unattended at any time. Consequently, all bills of lading covering outgoing shipment(s) submitted to CSI or its subcontractors by the Exhibitor will be checked at the time of pickup from the booth and corrected where discrepancies exist.
3. CSI and its subcontractors shall not be liable for any damage incurred during the handling of materials or equipment requiring special devices to properly load, place, or reload unless 14 days advance notice has been given to CSI in time to obtain the proper equipment.
4. CSI and its subcontractors shall not be responsible for any loss, delay, or damage due to events beyond their reasonable control which cannot be avoided by the exercise of due care and prudence, including without limitation, strikes, labor disputes, lockouts or work stoppages of any kind, fire, theft, windstorm, water, vandalism, terrorism, acts of war, utilities, and other events of force majeure. Any and all work performed by CSI or its subcontractors up to and including the occurrence of any of the above must be paid in full.
5. CSI and its subcontractors shall not be liable for ordinary wear and tear in handling of materials and/or equipment.
6. CSI and its subcontractors are not insurers; i.e., CSI does not insure the Exhibitor's property against loss or damage, nor does it provide for full replacement value should loss or damage occur. Insurance, if any, shall be obtained by the exhibitor. Amounts payable by CSI under this paragraph are based on the scope of the liability as herein set forth and are unrelated to the value of the Exhibitor's property. Provisions of this paragraph shall apply if Exhibitor's property is lost or damaged through performance or non performance of services by CSI, or from the negligence of CSI, its subcontractors or their respective employees. If such loss or damage occurs, the liability of CSI and its subcontractors shall be limited to a sum equal to \$.30 per pound per article, with a maximum liability of \$50.00 per item or \$1,000.00 per shipment, whichever is less. This amount shall be considered Exhibitor's agreed-upon damages and exclusive remedy.
7. CSI and its subcontractors shall not be liable to any extent whatsoever for any indirect, special, incidental, or consequential damages which may include, but are not limited to any actual, potential or assumed loss of profits or revenues, loss of use of equipment or products, or any collateral costs that may result from any loss or damage to Exhibitor's materials or any injury to Exhibitor's personnel which may make it impossible or impractical for Exhibitor to exhibit its materials.
8. CSI will not be bound to honor any claim or action brought against CSI or its subcontractors more than 60 days after the date of incident.
9. The Exhibitor agrees, in connection with the receipt, handling, temporary storage and reloading of its freight, that CSI and its subcontractors will provide these services as Exhibitor's agent and not as bailee or shipper. If any employee of CSI or its subcontractor sign a delivery receipt, bill of lading or other document, the parties agree that CSI or its subcontractor will do so as the Exhibitor's agent, and the Exhibitor accepts the responsibility thereof.
10. CSI and its subcontractors shall not be liable for shipments received without receipts, freight bills or specified unit. Such shipments will be delivered to booth without guarantee of piece count or condition.
11. Empty container labels will be available at the CSI Service Desk. Affixing the labels is the sole responsibility of the Exhibitor or its representative. It is understood that these labels are used for EMPTY STORAGE ONLY, and CSI and its subcontractors assume no responsibility or liability for loss or damage to contents while containers are in storage or for mislabeled containers.
12. In order to expedite removal of freight from the show site, CSI shall have the authority to change designated carriers, if assigned carriers do not pick up on time. Where no disposition is made by the exhibitor, freight will be taken to a warehouse and forced shipped on a carrier determined by CSI and the Exhibitor agrees to be responsible for payment of charges relating to such handling and shipping. CSI assumes no liability as a result of rerouting or handling.
13. Dry and cold storage – Exhibitor stores products at its own risk. CSI assumes no liability or responsibility for dry or cold storage.
14. The Exhibitor agrees, in the event of a dispute with CSI or its subcontractors related to any loss or damage to any of the Exhibitor's freight or equipment, that the Exhibitor will not withhold payment in any amount due to CSI for freight handling services or any other services provided by CSI or its subcontractor as an offset against the amount of the alleged loss or damage. Instead, the Exhibitor agrees to pay CSI prior to the close of the show for all such charges and further agrees that any claim the Exhibitor may have against CSI or its subcontractor shall be pursued independently by the Exhibitor as a completely separate transaction to be resolved on its own merits.